



APPLICATION NOTE: 410

Monitoring and documenting temperature/RH in warm environments

Many manufacturing processes use heat for production processes. It is important to monitor and document the temperature of these heater or ovens over time for quality assurance. The ThermaViewer with its flexibility in sample rates and displaying data makes is ideally suited for this purpose.

It can be set to sample and store temperature/RH at different rates. This allows for electronically buffering the temperature. For example, the ThermaViewer can be set to sample temperature every 15 seconds and store a value every 10 minutes. In this example, it will take 120 samples and then store the average value.

Two temperature/RH sensors are included so that temperature/RH can be monitored from two different sources.

Using a ThermaViewer is simple, with minimum set-up time required. It stores and display months and even years of temperature history for each of its two probes. Because it doesn't need paper charts or pens to draw the graph, there is no ongoing labor or expense of replacing charts or pens. The graph, unlike the old paper charts, is very easy to interpret, which means that every employee will become part of your quality assurance. Each time they glance at the ThermaViewer they will see a record of the past temperatures.

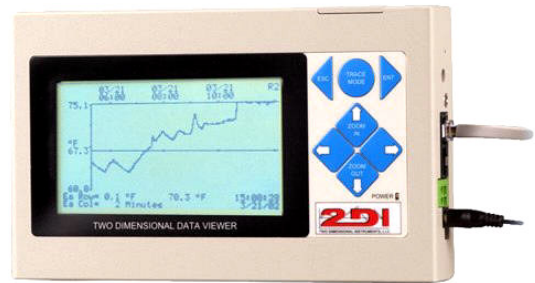

It needs no programming or maintenance. Simply plug the ThermaViewer into a wall socket and begin collecting and documenting temperature/RH immediately.

Installation of the ThermaViewer is a simple 5 step process:

1. Position the two sensors in the oven or near the heater..
2. Route and Plug in the two 20 foot cables (50 or 100 foot cables are available as an option).
3. Plug the power adaptor into a wall socket and into the ThermaViewer.
4. Attach the auto dialer (if purchased).
5. Set the time and monitoring frequency (see below for suggested settings).

What to Order:

- TDVDR-02 (2 sensors) \$ 749.00

Optional Items:

- Auto-dialer with cable² \$ 165.00
- 50 foot cable \$ 25.00
- 100 foot cable \$ 50.00

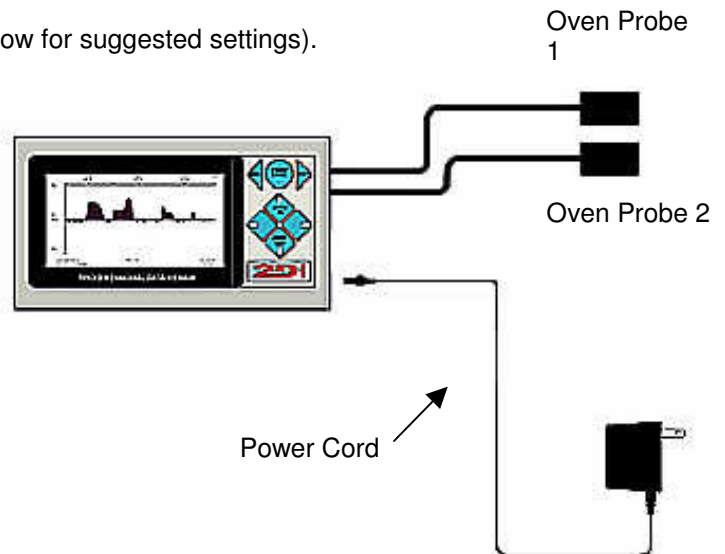



APPLICATION NOTE: 410

Installation and Setup

Mount the ThermaViewer display in an area that can easily be seen by everyone. Position each probe in the area to be measured.

The following are suggested settings for a hypothetical example. We will assume that we want to monitor inflow and oven temp/RH: The inflow air is normally around 72°F and the oven is supposed to maintain 175°F. We want to be alerted if the inflow air rises above 85°F for more than 30 minutes or falls below 60°F for more than 40 minutes. We also want to be alerted if the oven rises above 180°F for more than 60 minutes or falls below 60°F for more than 10 minutes.

You should use the settings required by your standards based on your quality assurance plan.

Suggested settings:

1 Probe (inflow air)		Probe 2 (Oven)	
Sample Data every	15 seconds	Sample Data every	15 seconds
Store Data every	10 minutes	Store Data every	10 minutes
Recorded Temperature	Average	Recorded Temperature	Average
Temperature Scale	F°	Temperature Scale	F°
Maximum Display Temperature	90°	Maximum Display Temperature	200°
Minimum Display Temperature	60°	Minimum Display Temperature	60°
Reference Line	72°	Reference Line	175°
Relay Enabled ¹		Relay Enabled ¹	
Activate Relay for	0:10 (min:sec)	Activate Relay for	0:10 (min:sec)
When Temp > 85° for 3 stored temperatures		When Temp > 180° for 6 stored temperatures	
When Temp < 60° for 4 stored temperatures		When Temp < 60° for 1 stored temperatures	

Setting the probes to sample data every 15 seconds and store data every 10 minutes causes the ThermaViewer to take forty samples then plot and store the average of those four readings. In this example both probes are set to sample and store data at the same rates, but this is not a requirement of the instrument. One probe could be set to sample temperature every 15 seconds and store data every 60 seconds and the second probe could be sampling data every 30 seconds and storing data every 30 minutes. Likewise one probe could be monitoring a freezer and the second one a 1000°C oven.

Downloading data:

The ThermaViewer will hold ten months of temperature/RH data for each probe with the settings listed above. If the stored interval is longer, a longer period of time will be covered. For example, if temperature is stored once every 60 minutes the ThermaViewer will store five years of data for each probe.

A regular schedule for downloading data from the ThermaViewer should be established so that a back up copy of the data is maintained in your computer. The ThermaViewer can also be programmed to automatically download data at regular intervals. Of course a cable between your computer and the ThermaViewer would have to remain in place. You can also print out a copy of the graph with the same program that downloads data to your computer (TView).

¹ Enable the relay only if you have an alarm or the optional auto-dialer wired to the relay. See application note 102